

# *Organomation*<sup>®</sup>

## **MICROVAP<sup>®</sup>**

### **Nitrogen Evaporation System**

Models  
11803 (Triple Plate)

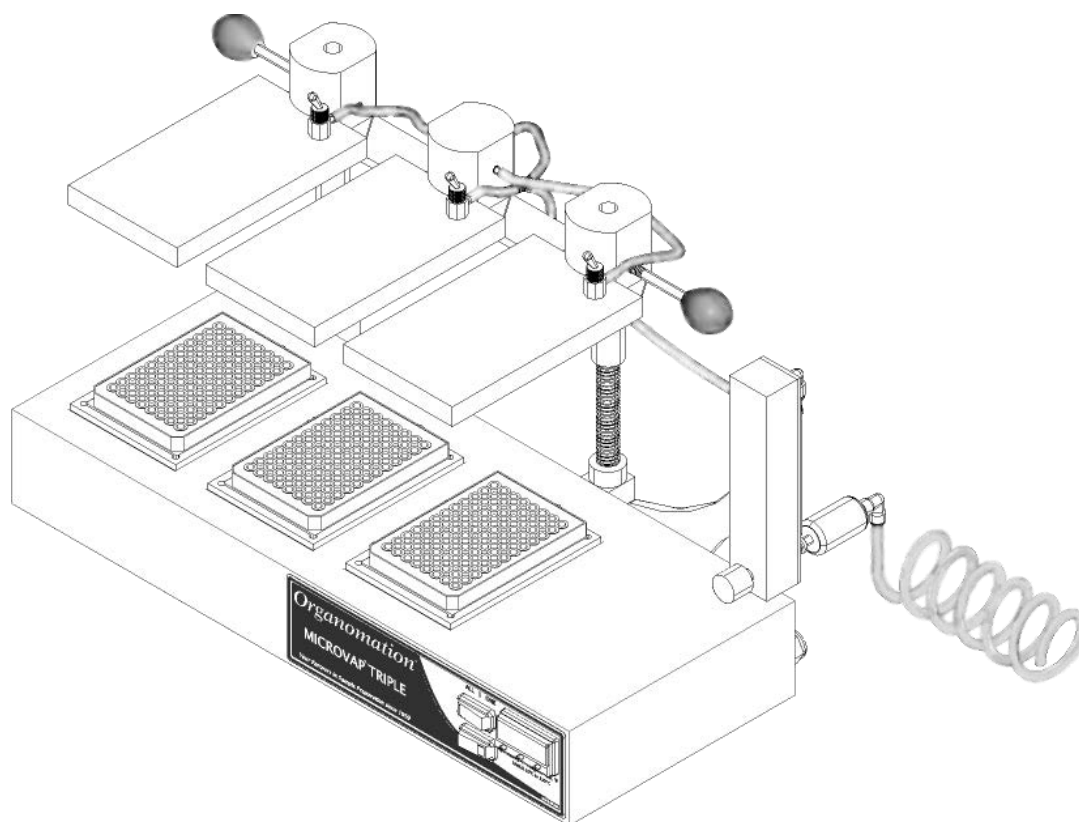

## **INSTRUCTION MANUAL**

266 RIVER ROAD WEST  
BERLIN, MA 01503  
U. S. A.

Tel: 888-838-7300

Fax: 978-838-2786

Email: [sales@organomation.com](mailto:sales@organomation.com)



**Introduction**

Instrument Items Shipped .....	4
Instrument Description .....	6
Instrument Part Identification .....	8

<b>Safety Considerations - Read before operation .....</b>	<b>7</b>
--	----------

**Installation**

Location .....	13
Bath Setup .....	15
Instrument Setup .....	8

**Operation**

Instrument Control Identification .....	18
Planning and Preparation .....	14
Bath Operation .....	15
Instrument Operation .....	19

<b>Maintenance and Cleaning .....</b>	<b>23</b>
---------------------------------------	-----------

<b>Trouble Shooting .....</b>	<b>24</b>
-------------------------------	-----------

<b>Technical Information .....</b>	<b>28</b>
------------------------------------	-----------

Parts List .....	8
Service and Returns .....	28
Shipping - Claims for damage or shortage .....	29
Specifications .....	30

**Items Shipped**

Carefully check the contents of all cartons received for damage which may have occurred in transit. Retain all cartons and packaging materials until all components have been checked against the packing slip, the component list below, and the equipment has been assembled and tested. Contact Organomation immediately if any damage or discrepancies are found.

Your shipment should contain one or more of the instruments shown below. Option codes are listed on the next page.

---

---

<b>ID #</b>	<b>Instrument Size</b>
<b>11803</b>	<b>Triple Plate MICROVAP Nitrogen evaporation system</b>
NA1804	Flowmeter Assembly with Mounting Bracket & Connector Tube 0-100 LPM for triple plate MICROVAP
NA1807	19ga x 2" Stainless Steel Needles, blunt end 24 dz for 3 Position MICROVAP (pre-installed)
B1803	OA-HEAT heater 540W, for triple plate MICROVAP

---

---

**Option Codes and additional items shipped**

The following list contains option codes and items which may have been shipped in conjunction with the standard parts shown on the previous page. Please check your packing list and order information carefully to determine if these items are included in your shipment. For a complete list of available accessories, please refer to the Accessories Section.

Your shipment may contain the following optional items:

<b>Option</b>	<b>Description</b>
-Z	OA-HEAT heating unit has been modified for the Type-Z Purge Positive Pressure bath option (passive operation). Additional parts include: differential pressure gauge, mounting bracket, and tubing.
-2	OA-HEAT heating unit is wired as a 240 Volt unit.

### Instrument Description

The MICROVAP Nitrogen Evaporation System is designed for general evaporation and / or concentration of analytical or biological samples in 96 well titer plates under controlled and reproducible conditions. Other micro well plate configurations are available.

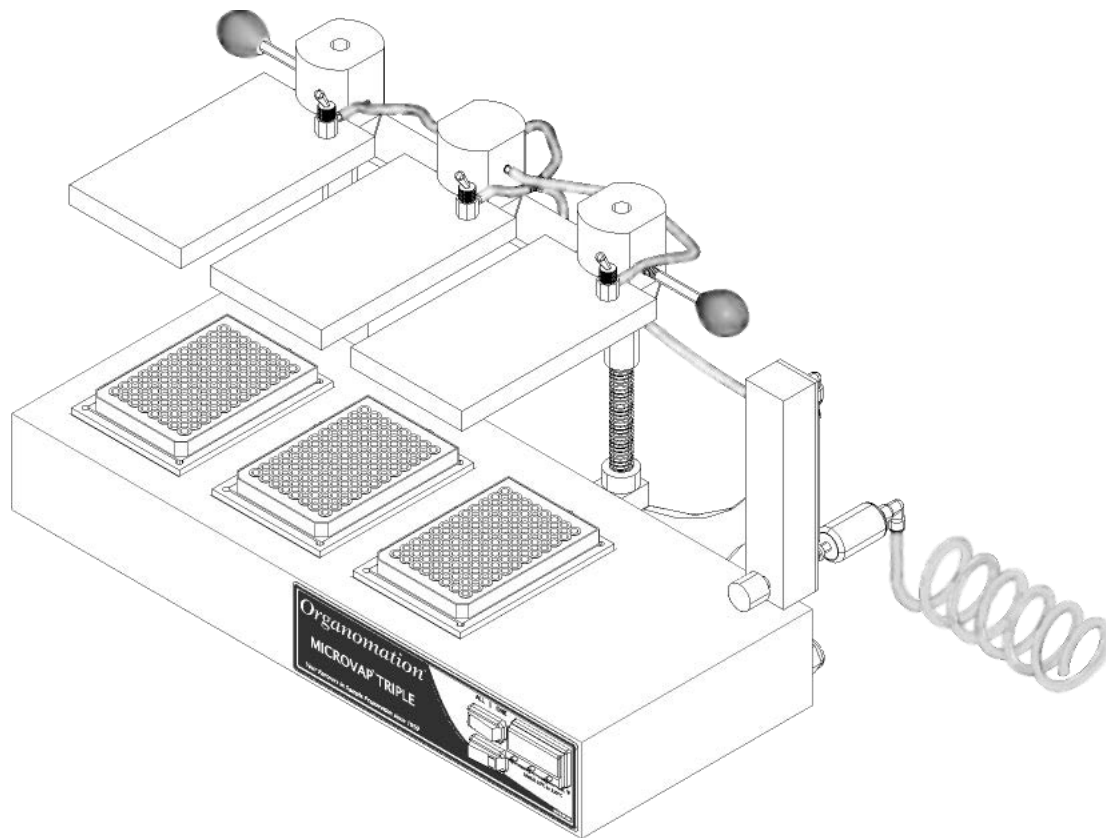

**Figure 1:**

Triple Plate MICROVAP;  
11803

## Safety Considerations

### READ THIS SECTION BEFORE EQUIPMENT OPERATION!

This equipment is designed for use in the Analytical or Environmental Laboratory by trained laboratory personnel for evaporative applications. Use of this equipment beyond its stated intended purpose and operating parameters is not recommended and will be the sole responsibility of the user. This equipment should not be modified or altered. Organomation assumes no liability for any misuse of or modification to this product and such misuse or modification will immediately void all warranties.

This equipment should be used in accordance with the operating instructions contained in this manual. For alternative uses not covered in this manual, please contact Organomation technical department for product suitability, safety, and alternative operating instructions.

The following are general safety guidelines recommended when using this product. Please consult your laboratory safety officer for any additional safety steps which may be necessary for your specific application or material.

1. Thoroughly review your MSDS (Material Safety Data Sheets) for all chemicals to be used with this equipment.
2. Do not use this equipment with materials with auto ignition points below 150 °C.
3. Hand and eye protection are required when using this product. Additional protection may be required with respect to the materials being used. Please consult your laboratory safety officer.
4. This product should only be used in a chemical fume hood with adequate ventilation.
5. Do not move the product when hot - BURN HAZARD!
6. Do not open bath enclosure while energized - SHOCK HAZARD!
7. Repairs of electrical components should be conducted by a trained electrical technician.  
Incorrect replacement parts or assembly may damage the product and create a serious safety hazard for the user. Factory repair is recommended.
8. Highly flammable materials such as Petroleum Ether should not be used with this product unless the Type-Z Purge positive pressure bath option is installed and operating.
9. Use of acidic or base materials may damage this product and is not recommended unless the product was ordered with the optional corrosion resistant coating.

Assembly Instructions: Triple Plate MICROVAP

1

Gather and identify all components.

- |           |                     |           |                                       |
|-----------|---------------------|-----------|---------------------------------------|
| <b>A.</b> | Heating Unit        | <b>G.</b> | Coiled Connector Tube Assembly        |
| <b>B.</b> | Instrument Manifold | <b>H.</b> | Hex Key [ 1/8" ]                      |
| <b>C.</b> | Thumb Screws (2)    | <b>I.</b> | Hex Key [ 5/32" ]                     |
| <b>D.</b> | Flowmeter           | <b>J.</b> | Offset Collars (2)                    |
| <b>E.</b> | Flowmeter Bracket   | <b>K.</b> | Stainless Steel Rods With Springs (2) |
| <b>F.</b> | Screws (4)          | <b>L.</b> | Tube (1) [Not Pictured]               |





Assembly Instructions: Triple Plate MICROVAP

2



Position heating unit [A] on a flat surface.

3

Remove screws from rear surface.

Position flowmeter bracket [E] over holes as shown.

Replace screws.

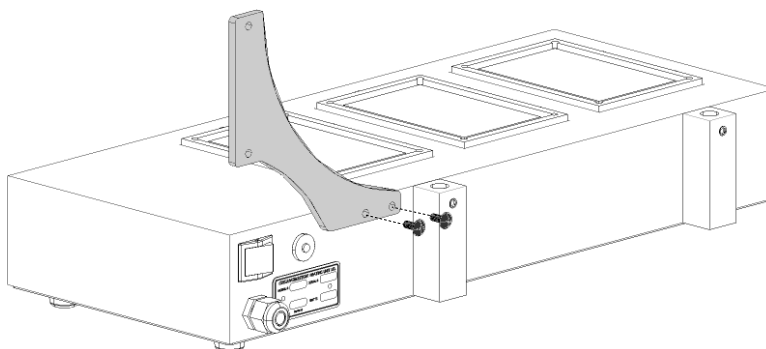

4

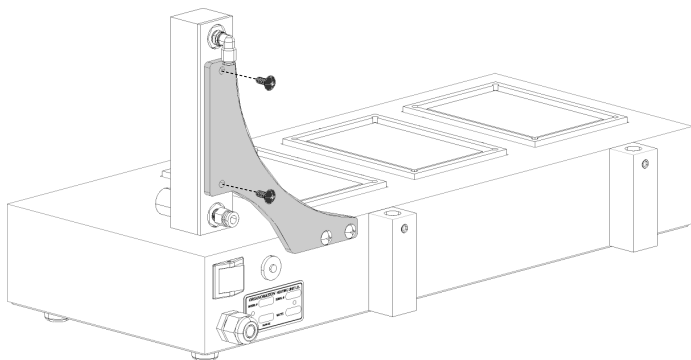

Remove screws from rear of flowmeter [D]

Position flowmeter over bracket holes as shown.

Replace screws.

## Assembly Instructions: Triple Plate MICROVAP

5

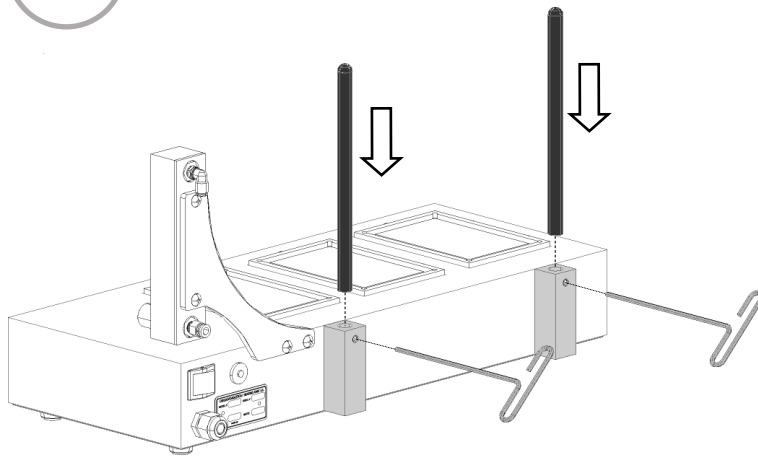

Use the 1/8" hex key [H] to loosen set screw on rear block.

Insert a stainless steel rod [K] into the each block.

Tighten the set screw to secure rod in place.

6

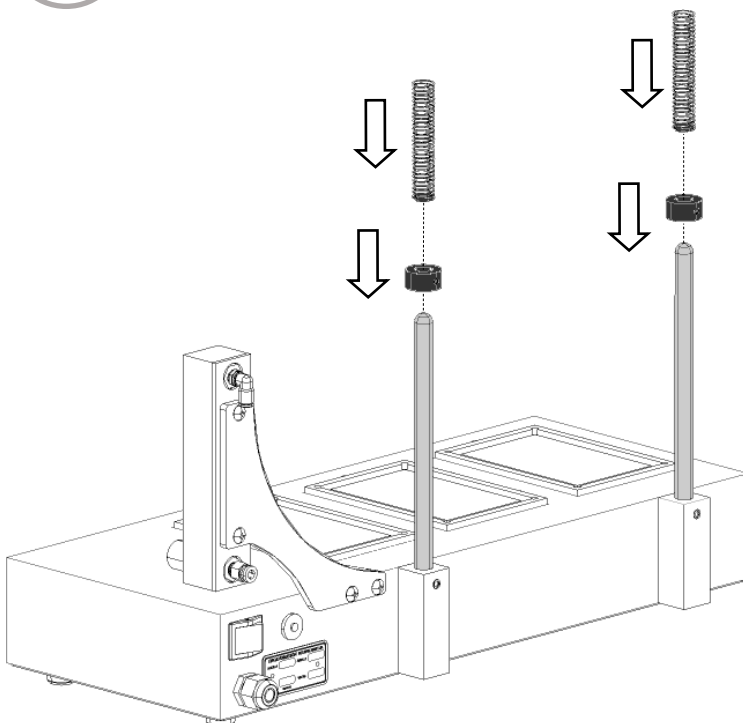

Place the offset collars [J] over the rods and lower until seated on the mounting blocks.

Place the compression springs [K] over the rods and lower until seated on the offset collars.

## Assembly Instructions: Triple Plate MICROVAP

7

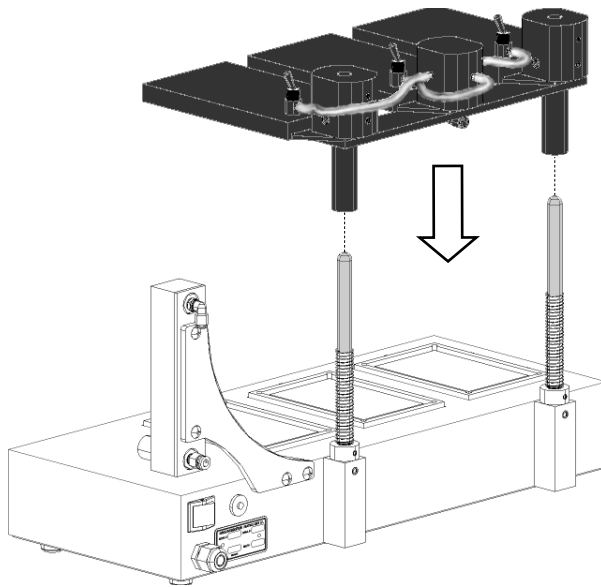

Place the instrument manifold [B] over the rods as shown.

Lower until seated.

8

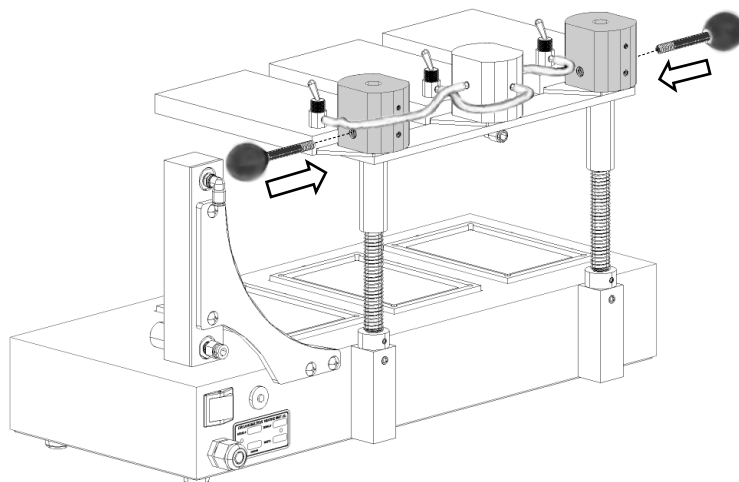

Thread the thumb screws [C] into the side holes of the manifold as shown.

## Assembly Instructions: Triple Plate MICROVAP

9

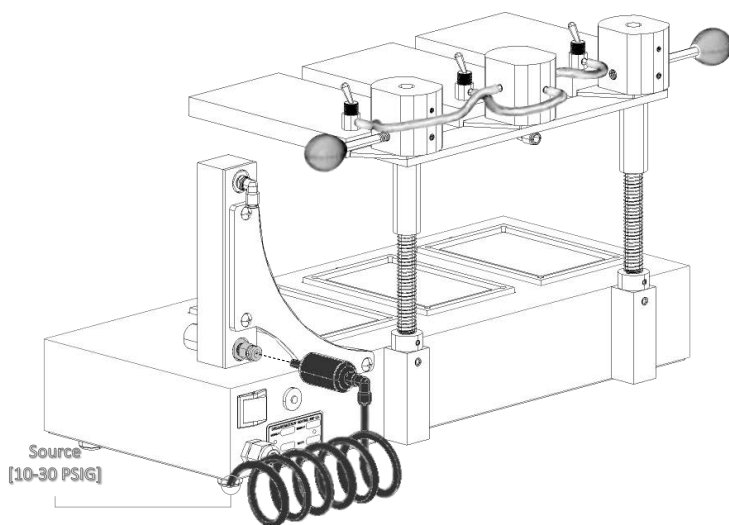

Attach the exposed end of the filter, in the coiled connector tube assembly [G], to the lower rear fitting of the flowmeter.

Attach the other end of the connector tube to a suitable gas source (10-30 PSIG).

10

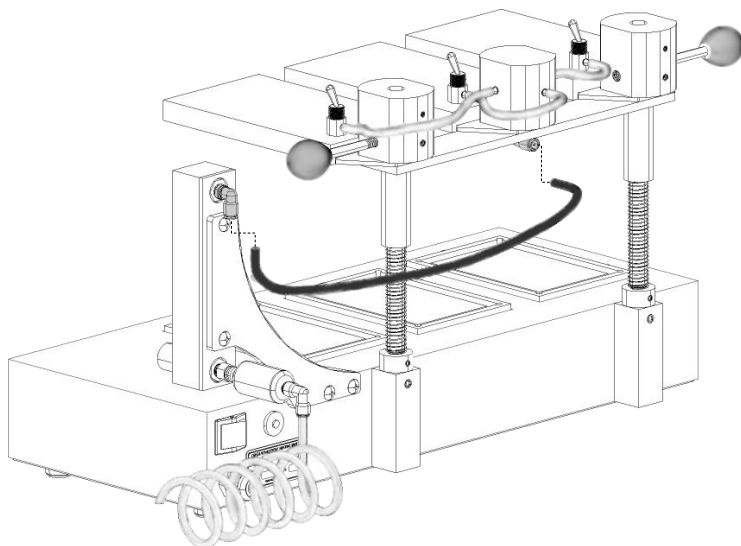

Attach the manifold gas tube [L] to the upper fitting on the rear of the flowmeter.

## Location

The MICROVAP Evaporator System should be located on a bench top or in a chemical fume hood if hazardous or flammable materials and solvents are to be used. The location should provide the necessary support services for the instrument. These include electrical power (required for heat unit) and a clean inert gas source (Air or Nitrogen). Please review the Specifications Section for further information.

## Heating unit Setup

1. Position the unit in a chemical fume hood.
2. Turn the main power switch to the “OFF” position.
3. Plug the bath electrical cord into a 3 wire grounded electrical outlet rated for 110-120 VAC, 50-60 Hz, single phase, 10 amps.

Optional 220 VAC baths are clearly marked and should be plugged into a 3 wire grounded electrical outlet rated for 220-240 VAC, 50-60 Hz, single phase, 10 amps.

4. **Pressure Reducing Regulator Option - If you do not have this option, proceed to the next section.**

When purchased with a MICROVAP System, this item is pre-installed onto the flowmeter, between the flowmeter and the Connector Tube. To install a pressure reducing regulator, please follow the instructions and figure below:

- A. Remove the flowmeter from the bracket.
- B. Remove the Connector Tube and fitting from the flowmeter.
- C. Re-connect the flowmeter to the bracket.
- D. Connect the Pressure Reducing Regulator to the lower fitting on the back of the flowmeter. Position the regulator such that the adjustment knob is straight up and the gauge points away from the bath.
- E. Connect the Connector Tube to the regulator.

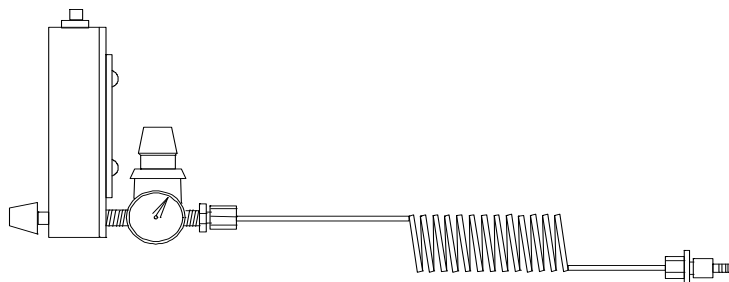

Flowmeter Regulator Assembly shown with Gas Connector Tube.

**Planning and Preparation**

It is important to understand the procedures and equipment operation prior to the use of the equipment. High speed nitrogen evaporation requires a balance of sample volume, nitrogen flow, temperature, needle position and adjustment. Improper use can impair performance, contaminate samples or result in loss of samples. Environmental conditions are also important, examples include use of dry or wet heating media, hood airborne contaminants, gas purge purity, and sample handling procedures. If you are unfamiliar with the use of the MICROVAP System or are working with a new procedure, it is recommended that a trial run be made using a sample blank to determine optimal operating conditions.

The MICROVAP System is designed to handle one to three 96 well plates simultaneously up to the capacity of the equipment. 96 position deep well plates may also be used. Other well plates of different capacities can also be accommodated, consult Organomation for details.

The MICROVAP System is manufactured utilizing inert materials. The white translucent and black coiled tubing used is free of phthalate presence.

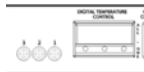

## Bath Controls Diagram

Picture ID	Description	Function
A	<u>Main Power Switch</u>	Turns power to the unit on and off
B	<u>Digital Temperature Controller</u>	Adjusts the bath temperature
C	<u>Amber Light</u>	Indicates heating when heaters are energized, will cycle at temperature
D	<u>Black Rocker Switch</u>	Heater power to samples
E	<u>Heat Plate Control</u>	Toggles between heat being supplied to the first heating position and all heating positions
F	<u>Circuit Breaker</u>	Protects electric circuit and allows the instrument to be reset.

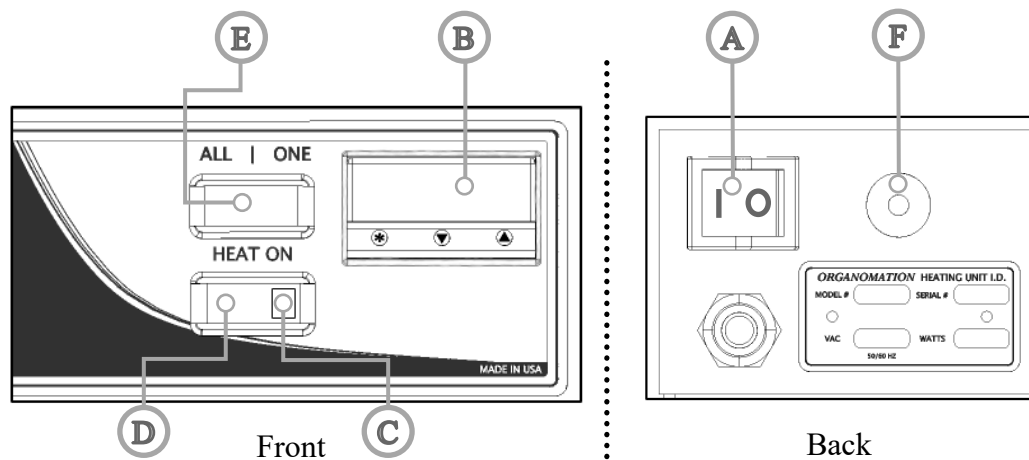
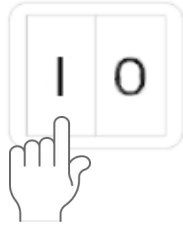

Figure 4: Layout for 11803

**Bath Operation**

1



Turn the main power switch [A] on.

\*The illuminated portion should glow.

2

**Digital Temperature Controller [B]:**

Adjust the digital controller to the desired temperature set point.

2a

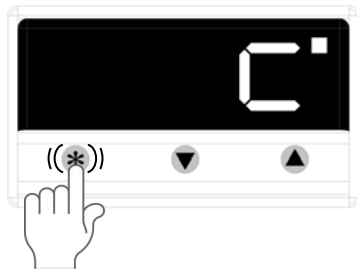

To view the current set point:  
hold the \* key.

2b

To change the current set point:  
hold the \* key and press either the ▼ or ▲ keys.

\*This setting will be retained even after the system is turned off.

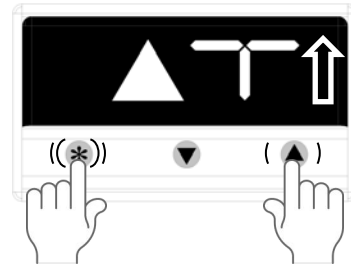

2c



To change the units of measure (°C or °F):  
press and hold the ▼ and ▲ keys for 3 seconds.

Navigate to

hold \* and press ▲ to adjust to level “2”

Navigate to

hold \* and press ▼ or ▲ to adjust to °C or °F.

Press and hold ▼ and ▲ to save settings.



Bath Operation

3

Triple Plate MICROVAP

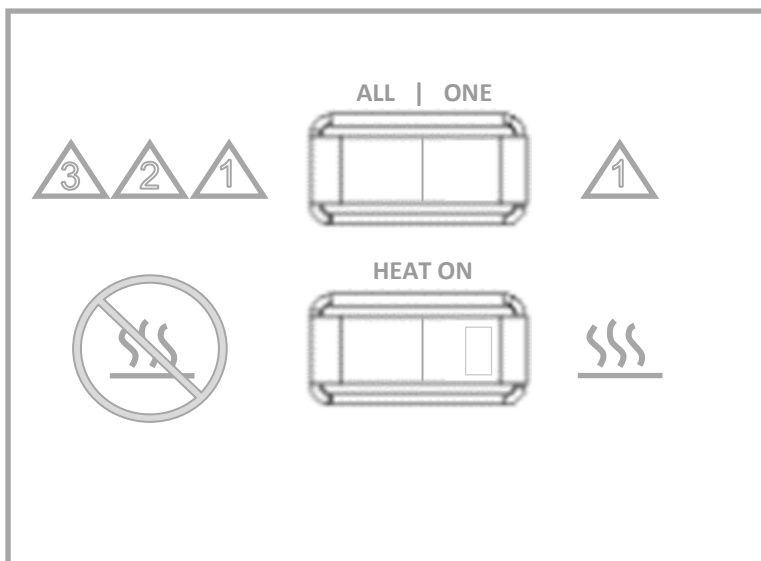
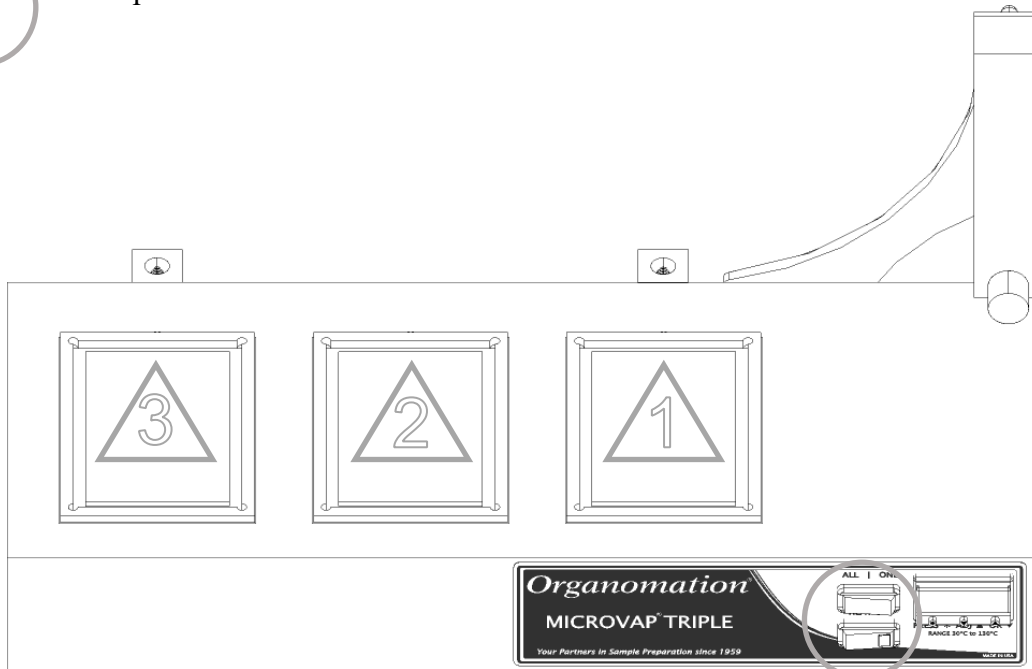

Switch the black rocker switch [E] to the right to power only the first position. And to the left to power all three positions.

Switch the black rocker switch [D] to the right to power on the heating blocks.

## Instrument Controls Diagram: Triple Plate MICROVAP

Picture ID	Description	Function
F	<u>Thumb Knob</u>	Locks manifold position when tightened
G	<u>Manifold Gas Valve</u>	Open or close gas flow to distribution manifold
H	<u>Flow Meter Valve</u>	Controls flow rate of gas from supply
I	<u>Heat Block</u>	Medium for heating samples
J	<u>Offset Collar</u>	Alters stopping height for manifold

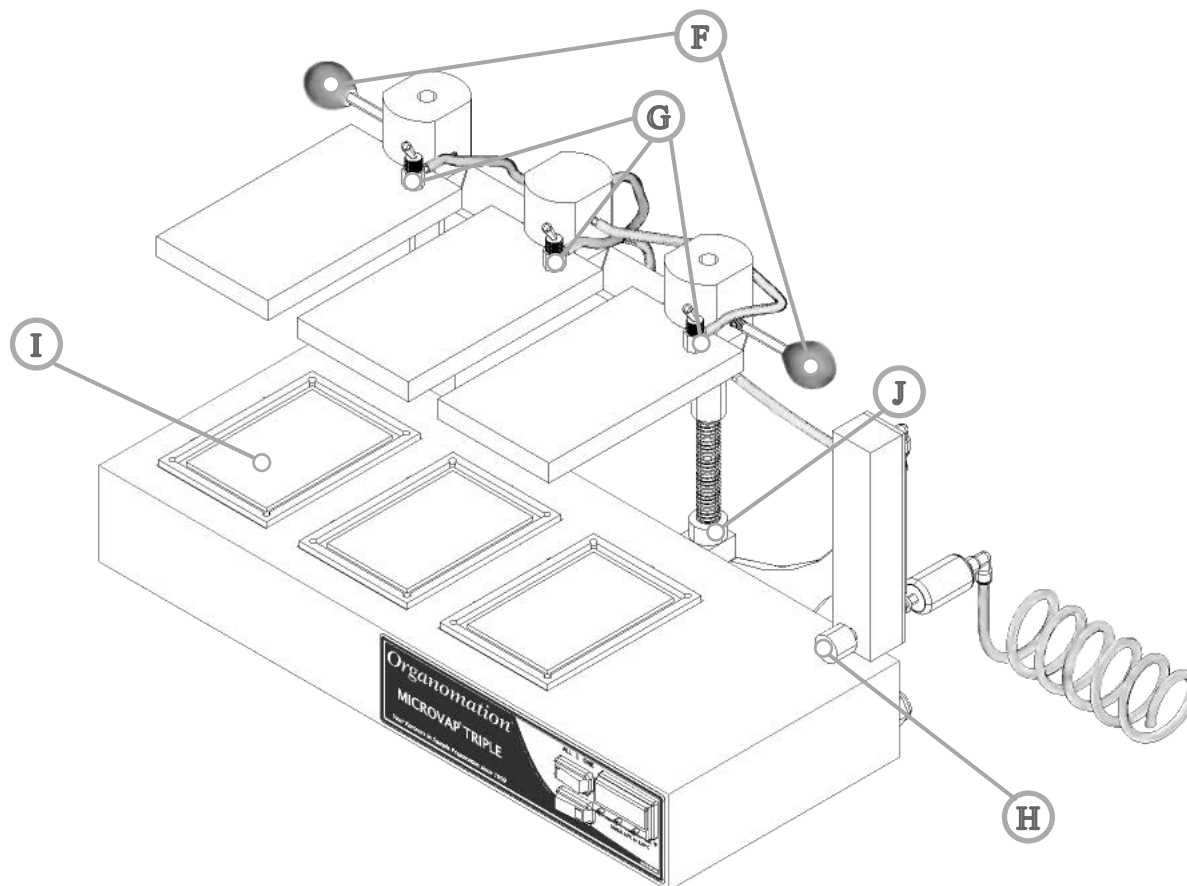

**Figure 6:** General Triple Plate MICROVAP Layout

**Instrument Operation: Triple Plate MICROVAP**

1

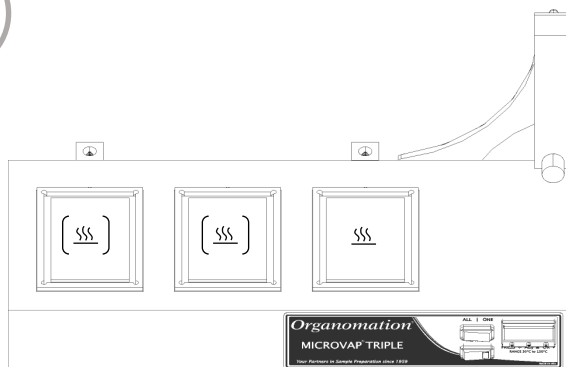

Preheat the heat block(s).

2

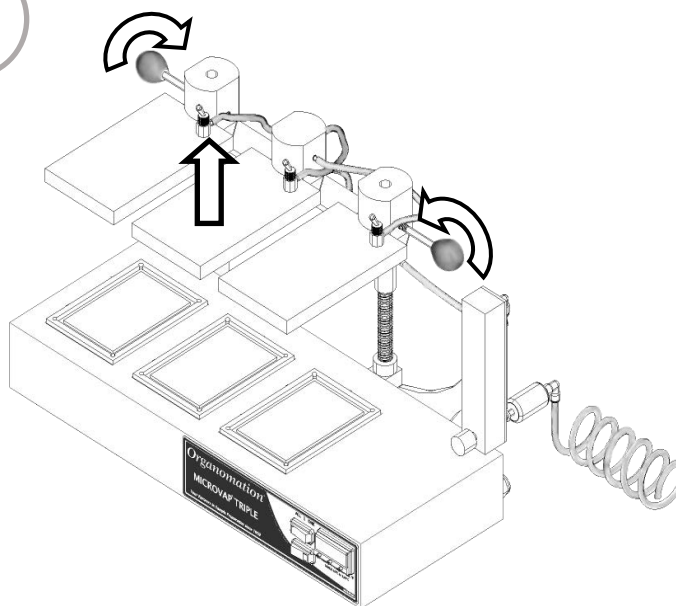

Raise the manifold upwards.

\*Loosen thumb knobs if necessary

3

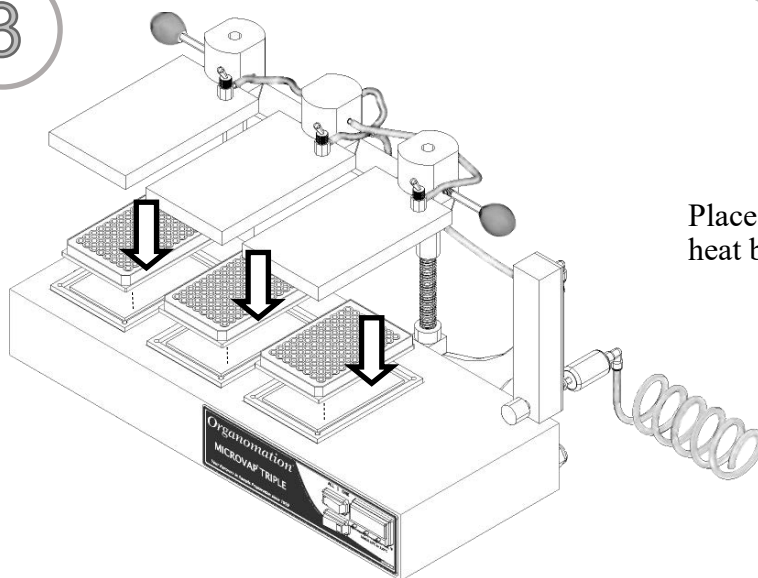

Place the well plate(s) on the heat block(s)

**Instrument Operation: Triple Plate MICROVAP**

4

Lower your manifold above the samples.

4a

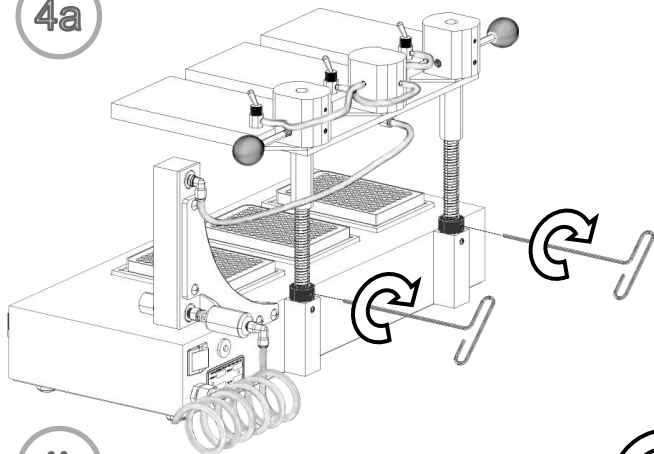

Adjust the offset collar to the desired stopping height of the instrument manifold using the 5/32 hex key.

4b

Loosen the manifold thumb knobs to adjust the manifold along the rod.

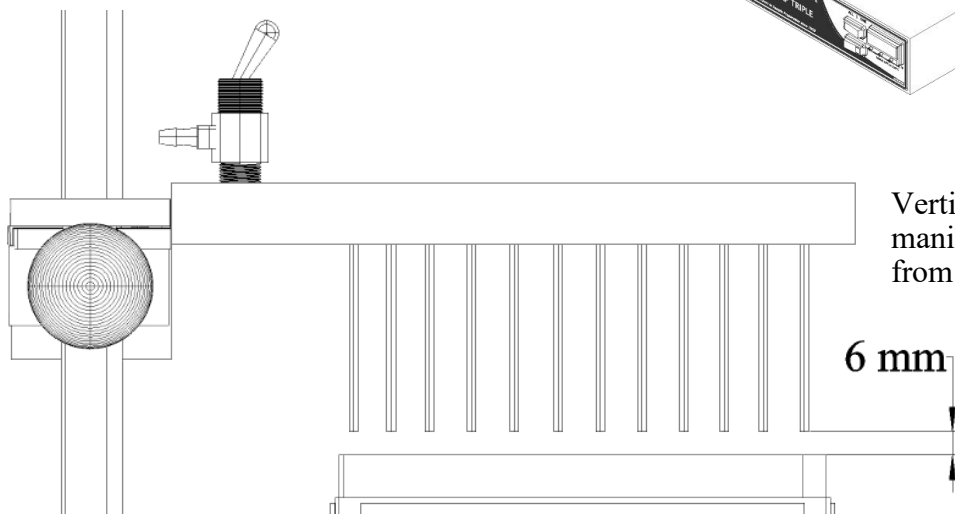
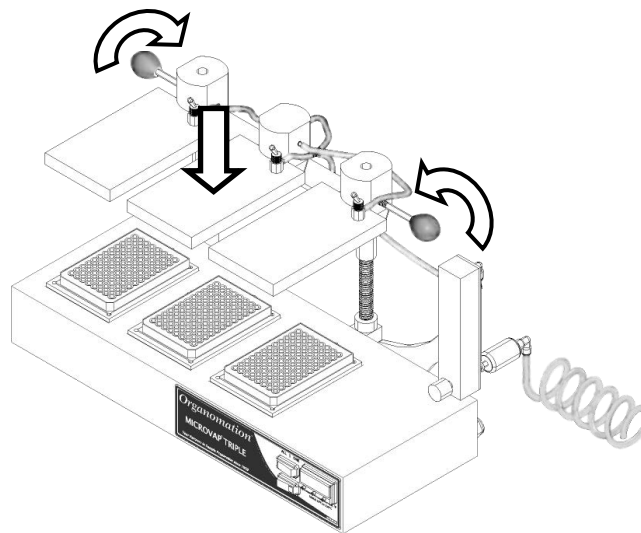

Vertically position the manifold 6mm away from the plate.

6 mm

**Instrument Operation: Triple Plate MICROVAP**

5

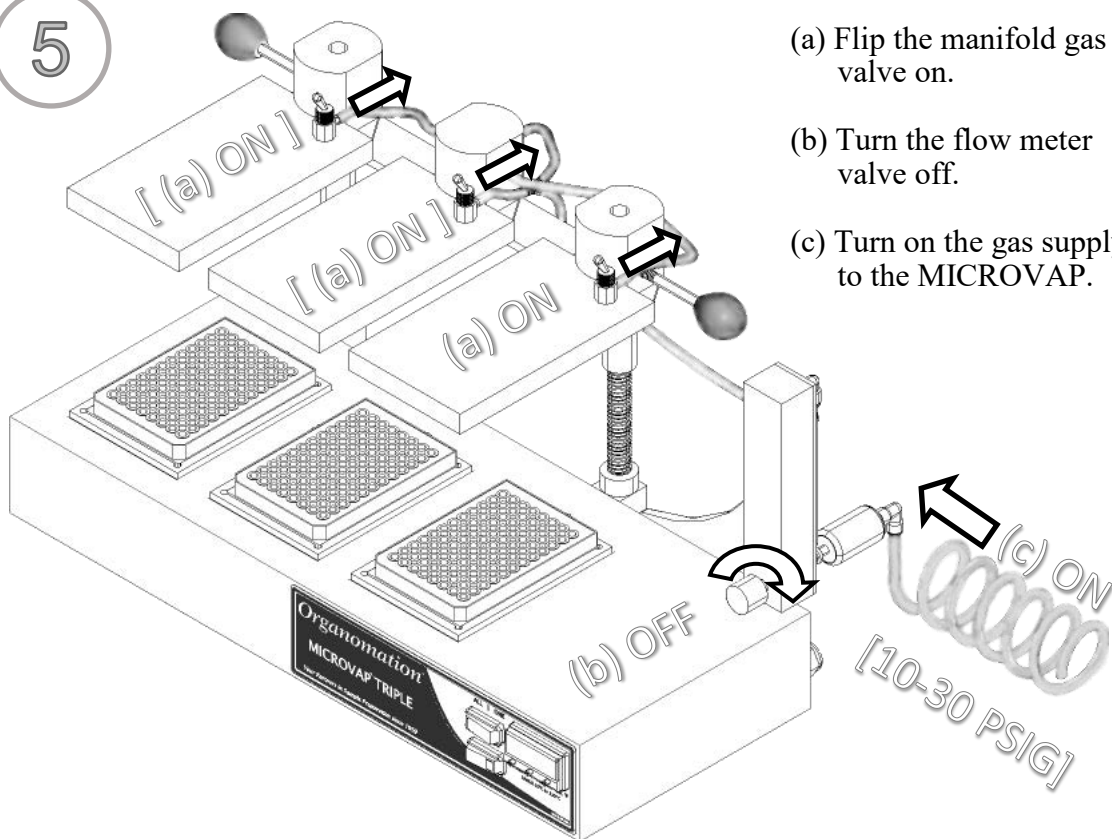

- (a) Flip the manifold gas valve on.
- (b) Turn the flow meter valve off.
- (c) Turn on the gas supply to the MICROVAP.

6

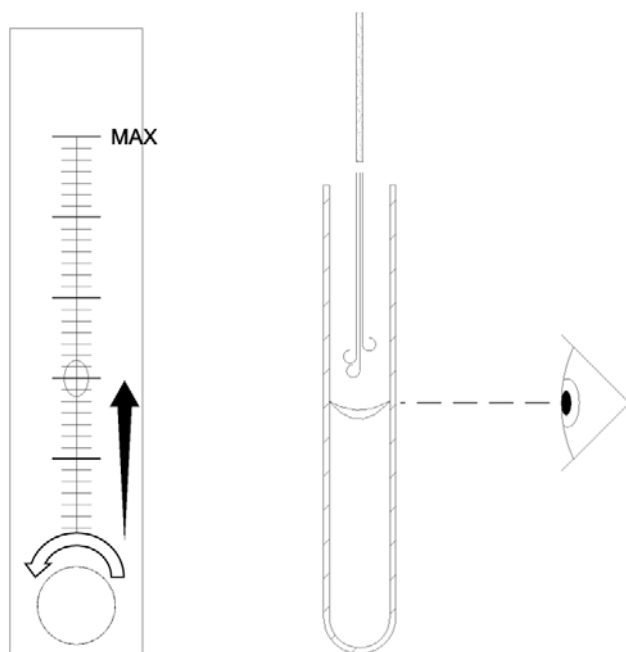

Using the flow meter valve:

Slowly increase the gas flow until a visible dimple appears on the surface of the solution.

**Instrument Operation (Post-Evaporation): Triple Plate MICROVAP**

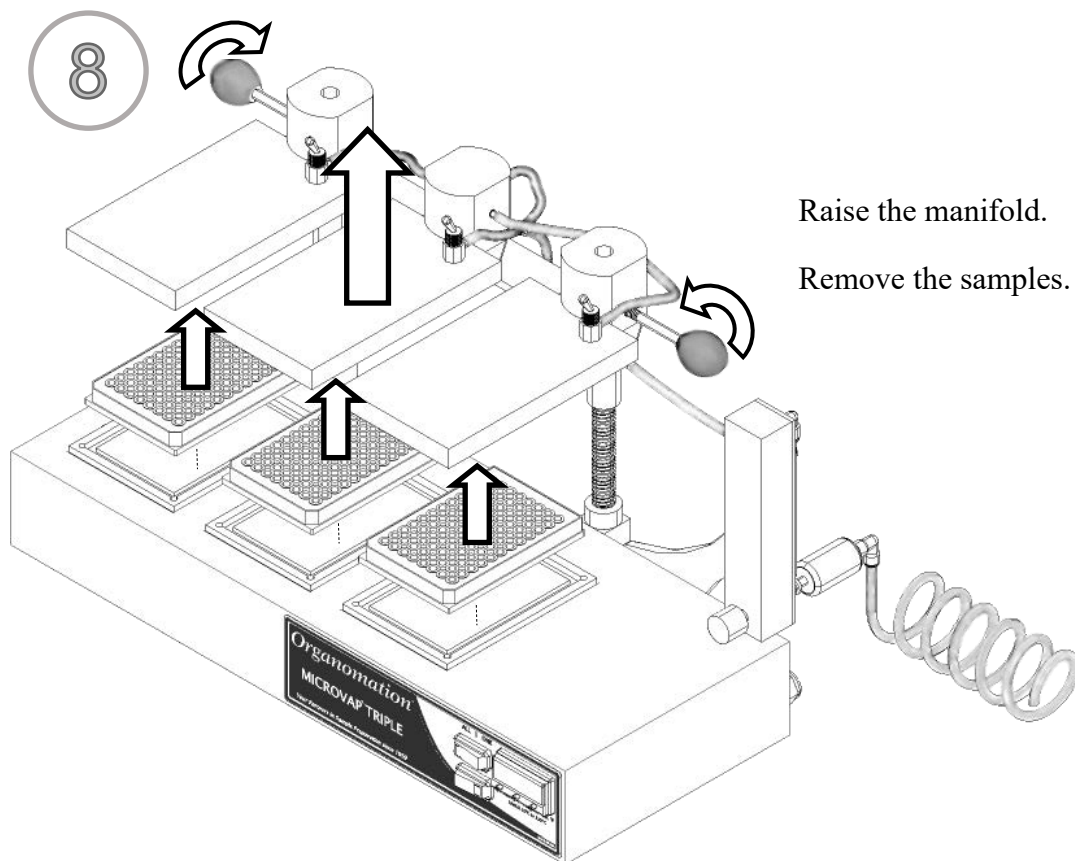
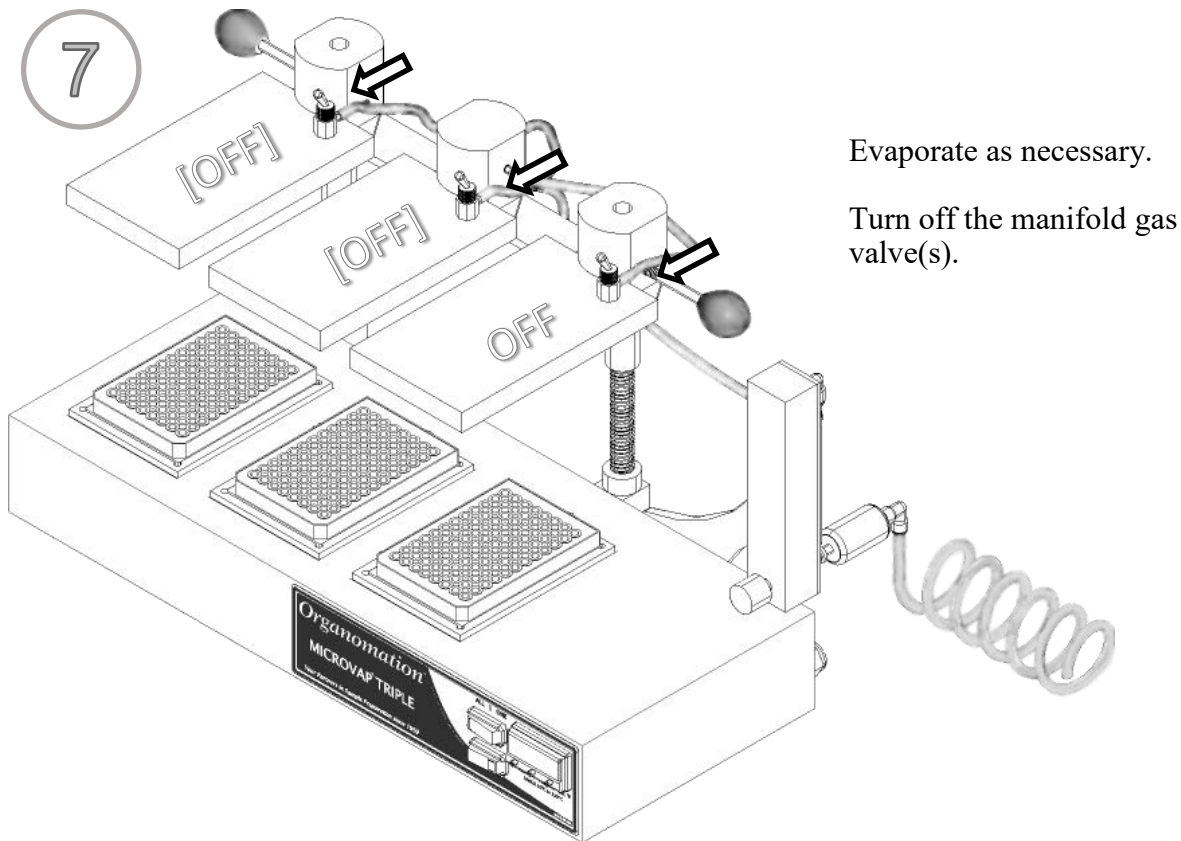

### Maintenance and Cleaning

The MICROVAP Evaporation system is manufactured from extremely durable materials and may last for years if operated and maintained properly. The following guidelines are recommended for use with MICROVAP systems.

- Cleaning - The metal components may be cleaned with a soft cloth or damp sponge.
- Epoxy coated parts (blue in color) should be cleaned with non-abrasive materials only, otherwise scratching will result and the coating will be compromised.
- Acidic Environment - When in contact with or exposed to acidic materials, vapors, or samples. The instrument should be cleaned immediately after use and neutralized with a suitable mild base solution of sodium bicarbonate or similar material followed by a clean water wipe. Prolonged contact with acidic materials may damage the instrument unless precautions are taken.
- Needles - Needles may be cleaned periodically as needed by rinsing the tips with a squirt bottle.
- Immersion - The bath case is water resistant, not water tight. Under no circumstances should the bath be immersed in any liquid or placed in a location where this may occur.

SYMPTOMS	CAUSES	SOLUTIONS
<b>No Power to unit.</b>	Electrical outlet not energized. Unit power cord not plugged in. Internal electrical fault.	Energize electrical outlet. Plug in bath power cord. Contact factory for instructions.
<b>Unit does not heat.</b> (heat light is on)	Bad wire connection. Defective high temperature protection switch. Defective SSR (relay)	Bath will require service, contact factory for instructions.
<b>No temperature control.</b> (temperature continues to rise)	Defective digital control	Replace controller, contact factory for instructions.
<b>Surface deterioration on equipment.</b>	Use of acidic materials in or near equipment.	Clean carefully with soft cloth. Remove source of acidic presence.
<b>Phthalate Contamination</b>	Human error	Purchase Phthalate free tubing. Exercise better handling procedures, avoid latex gloves, hand cream, rubber tubing.
<b>Inconsistent evaporation rates.</b> (or excessive Nitrogen use)	Nitrogen leaks. Missing needles Incorrectly seated hoist assembly	Check all connections, soap/water. Use luer plugs for positions not in use (15& 24 Position only) Lift up assembly and reposition



### Calibration of CAL3300 Digital Thermometer

If the controller and heat block temperature readings are different, then the CAL3300 Digital Thermometer will require calibration. The controller readings can be adjusted using both one-point and two-point calibration settings. Calibration at the temperature used most frequently will yield the most accurate results. If this temperature is unknown or if the unit will be used at more than one temperature, then calibration at 45 °C is recommended as a standard mid-range temperature.

#### One-Point Calibration

To make an equal adjustment across the full scale of the controller, adjust the setting: **2Ero**

1. Determine the temperature discrepancy between the heat block and the controller:
  - a. Heat the bath to a desired temperature set point and wait for the temperature on the controller display to stabilize
  - b. Take a temperature reading on the surface of the heat block with an external thermometer  
\*Note: You can use a metal block with a hole drilled for the thermometer, placed on the heat block, if you have one available.
  - c. Mark down the temperature discrepancy; where, heat block reading - controller reading = discrepancy.  
For example:

Heat block reading = 43 °C  
Controller reading = 45 °C  
43 - 45 = (-) 2

or,

Heat block reading = 47 °C  
Controller reading = 45 °C  
47 - 45 = 2

2. Once the temperature discrepancy has been determined, press and hold both ▲ and ▼ simultaneously until the screen reads **tune**
3. Release the buttons, and push ▼ until the screen reads **LEUL**
4. Hold \* and press ▼ until the screen reads 3, then release \*
5. Press ▲ until the screen reads **2Ero**

### One-Point Calibration (Continued)

6. Hold \* and press ▲ or ▼ to adjust **2E r 0** to the calculated discrepancy.
  - Use ▼ for negative (-) values
  - Use ▲ for positive (+) values
7. Once the correction has been entered, release \*
8. Press and hold both ▲ and ▼ simultaneously to save the new settings for controller calibration

### Two-Point Calibration

When operating the unit at various set point temperatures, then it may be necessary to make an adjustment that increases, or decreases, linearly across the scale to correct a range of errors; to do so, adjust the **SPAN** setting:

1. Determine the temperature range discrepancy between the heat block and the controller, at both the low end and the high end of the scale:
  - a. Heat the bath to a low temperature set point and wait for the temperature on the controller display to stabilize
  - b. Take a temperature reading on the surface of the heat block with an external thermometer ( $T_1$ )  
\*Note: You can use a metal block with a hole drilled for the thermometer, placed on the heat block, if you have one available.
  - c. Mark down the temperature error ( $E_1$ ); where, heat block reading - controller reading = error.
  - d. Repeat steps 1(a) through 1(c), at a high temperature set point, and mark down the values obtained for  $T_2$  and  $E_2$ .
  - e. To calculate the discrepancy range, substitute the values for  $T_1$ ,  $T_2$ ,  $E_1$ , and  $E_2$  into the following equation:

$$\frac{E_2 - E_1}{T_2 - T_1} \times 130 = \text{Discrepancy Range}$$

**Two-Point Calibration (Continued)**

For example:

*Low End:*

Heat block reading ( $T_1$ ) = 43 °C  
 Controller reading = 45 °C  
 Error reading ( $E_1$ ) = (-) 2 °C

*High End:*

Heat block reading ( $T_2$ ) = 94 °C  
 Controller reading = 100 °C  
 Error reading ( $E_2$ ) = (-) 6 °C

$$\frac{(-6) - (-2)}{94 - 43} \times 130 = \frac{(-4) \times 130}{51} = (-)10.2$$

2. Once the temperature discrepancy range has been determined, press and hold both ▲ and ▼ simultaneously until the screen reads **TUNE**
3. Release the buttons, and push ▼ until the screen reads **LEVL**
4. Hold \* and press ▼ until the screen reads 3, then release \*
5. Press ▲ until the screen reads **SPAN**
6. Hold \* and press ▲ or ▼ to adjust **SPAN** to the calculated discrepancy range.
  - Use ▼ for negative (-) values
  - Use ▲ for positive (+) values
7. Once the correction has been entered, release \*
8. Press and hold both ▲ and ▼ simultaneously to save the new settings for controller calibration

## Service and Returns

In the event a product purchased from Organomation needs service or must be returned please follow the outlined procedures below.

### 1) **Contact Organomation Technical Support Department**

Before returning any product to Organomation Associates for any reason, please contact the Technical Support Department, toll free at 888-838-7300 or email [sales@organomation.com](mailto:sales@organomation.com) Support is available Monday through Friday from 8:30 AM to 4:30 PM EST. Support is available free of charge to customers of Organomation in good standing for all products manufactured by Organomation.

### 2) **Pack the product for return shipment**

The product should be packaged in its original shipping carton if available. If other packaging is required, use a suitable shipping container which will allow a minimum of two (2) inches clearance between the product and the side walls of the shipping carton. Peanuts, semi rigid foam, cardboard, and other items may be used inside for packaging. Care should be taken when packaging heavy items. Some packaging, such as peanuts, will allow the item to shift in transit and may result in damage.

### 3) **Insurance**

Most common carriers offer insurance. UPS and Federal Express automatically insure your product up to \$100.00 without charge. It is highly recommended that you insure your product. **Organomation is not liable for any return shipping damages.**

### 4) **Documentation**

When returning items to Organomation, a Return Authorization Form provided by Organomation must be included with the following information: Contact persons name and phone number, return address, and statement of the problem.

### 5) **How will your return be handled?**

Organomation will evaluate the returned item for damage. If the return is a repair, the product will be examined for problems and a repair estimate will be made. The contact person will be contacted, at which time a Purchase Order will be requested. After the PO is issued, the product will be repaired and return shipped. Most repairs are done within a 24 hour period. Items returned for credit will be evaluated and your account credited after the item is received. The contact person will be notified immediately in the event shipping damage has occurred.

**Shipping - Claims for damage and shortage**

Organomation Associates Inc. makes a sincere effort to ensure your purchase is properly packed and all items listed on the packing slip are in fact enclosed with the shipment. In the event that your purchase is damaged or if any items are missing, please follow the procedures below.

- 1) All packaging materials must be retained until the issue is resolved.
- 2) Thoroughly search all packing materials for the missing items. Review your packing list for back ordered items and the manual for a list of items affiliated with your purchase.
- 3) Contact Organomation immediately at 888-838-7300 or sales@organomation.com
- 4) If a damaged item needs to be replaced, Organomation will send this item under warranty at no charge. The damaged item must be returned to Organomation. Please follow the instructions listed in the Service and Returns section. **Important - items not returned or which are further damaged or destroyed in transit are the responsibility of the customer and will be billable.**
- 5) No claims for shipping damage or shortage will be accepted after 15 days of receipt of the items by the purchaser.
- 6) **Please contact Organomation prior to making any returns.**

All items should be returned to:

**Organomation Associates, Inc.  
266 River Road West  
Berlin, MA 01503**

**Specifications**

- Electrical Requirements:** 120 or 240 VAC single phase, non switchable, 50 - 60 Hz.  
3 wire grounded outlet required.  
Model 11803 3 Position unit 540 W
- Water Services Required:** None.
- Gas Services Required:** Nitrogen, clean air, or other inert gas,  
5 - 30 Psig, adjustable.  
Flow indication standard with all complete MICROVAP systems.
- Sample Sizes Accepted:** 96 well standard and deep titer plates.
- Sample Types Utilized:** Organic Solvents with Boiling Point range 30 - 130 Celsius.  
Water and aqueous solutions.
- Safety Provisions:** 3 wire grounded power cord.  
High Temperature Protection Switch  
Digital temperature controlled unit.  
Optional Type-Z positive pressure bath purge.